

# DESIGN YOUR STEPPING ACTUATOR

STEPS IN ONE DIRECTION WITHOUT HARD STOPS-GREAT FOR FEEDING, CROWDING, SPREADING



BORE	RACKS	SERIES SYMBOL
5/8	1	S1
1	1	S2
1	2	S22
1 3/8	1	S3
1 3/8	2	S32
2	1	S4
2	2	S42

ROTATION SYMBOL	
CLOCKWISE	CW
COUNTER CLOCKWISE	CCW

OPTION	OPERATION CONTROLLED			NEEDLE VALVE POSITION
	DRIVE	RESET	BOTH	
FLOW CONTROL	1F	2F	3F	1,2,3 or 4
CUSHION	1C	2C	3C	1,2,3 or 4
BUMPER	1Q	2Q	3Q	
ADJUSTABLE ROTATION	1A	2A	3A	

SERIES	SYMBOL
S1	10.32*
S2,S22	1/8 NPT
S3,S32	1/4 NPT
S4,S42	1/4 NPT

\*1/8 NPT OPTIONAL, NO COST  
OTHER SIZES TO ORDER

PLATE	SYMBOL
BOTTOM	M
FRONT	N
REAR	P

SEE CATALOG PAGE 42

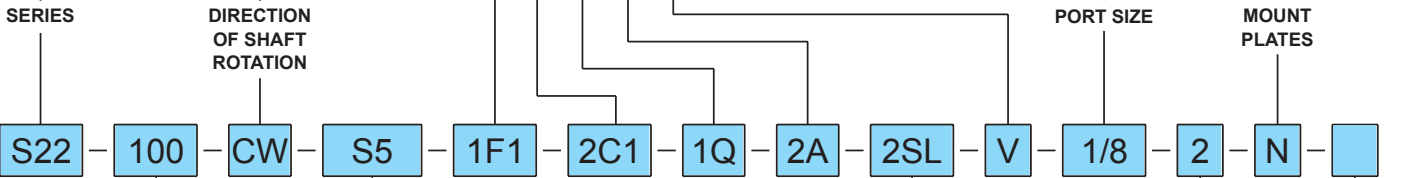

SHAFT ROTATION ANGLE

OPTIONAL ANGLES:  
30, 45, 60, 90, 100, 120, 180, 190, 270, 360, 370, 540, 550, 720, 730, OR AS SPECIFIED

MULTI-ANGLE S22, S32, S42:  
2 ANGLE: A-B  
3 ANGLE: A-B-C  
4 ANGLE: A-B-C-D

SUM TOTAL 360 DEG. MAXIMUM

SHAFT SIZE

SERIES	SYMBOL	OPTION SYMBOL
S1	S37	-
S2,S22	S5	D5
S3,S32	S75	-
S4,S42	S10	D10

DIMENSIONS: SEE CATALOG PAGE 43  
SPECIALS: SEND SKETCH

S=SINGLE END 37=.375 DIA.  
D=DOUBLE END 5=.500 DIA.  
75=.750 DIA.  
10=1.000 DIA.

MAGNETIC CONTROL OPTION

POSITION	CONTROLS	OUTPUT CIRCUIT	LEAD
1	DRIVE	R NPN Sink	L 9' Lead
2	RESET	S PNP Source	C Connector
3	BOTH	G Reed	
		N No Switch	
		Mag Only	

PORT POSITION

1, 2, 3, 4, 5  
NO COST

NOTE: PORT CANNOT BE ON SAME SIDE AS NEEDLE VALVE

HEAVY DUTY: A or K

## CALCULATED TORQUE IN INCH-POUNDS

Deduct 10% for friction

UNIT	OPERATING PRESSURE IN PSI				
	25	50	60	80	100
S1	3.8	7.6	9.2	12.3	15.3
S2	12.2	24.5	29.4	39.2	49
S22	24.4	49	58.8	-	-
S3	37.2	74.5	89.4	119	149
S32	74.5	149	-	-	-
S4	86.5	173	208	277	346
S42	173	346	415	-	-

## SEAL REPAIR KITS

PART NUMBERS FOR SEAL REPAIR KITS

FILL IN UNIT SERIES AND ALL RELATED OPTIONS:

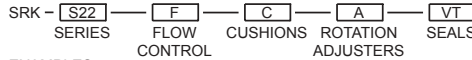

EXAMPLES:  
SEAL KIT FOR S2-90-CW-S5-1F2-2A-V-1/8-1 = SRK-S2-F-A-V  
NOTE: IF NO OPTIONS, SPECIFY SRK-S2-STD.

When an option is not required, leave blank.

Write out any special requirements in English or provide a dimensioned sketch. Rotomation can provide units to almost any configuration.

To expedite the order of a duplicate of a prior unit, refer to prior invoice/serial number stamped on the unit body.

Flow control and cushion cannot be installed in same end cap. Flow control in S1 10.32 port only.

## STEPPING ACTUATOR OPERATION

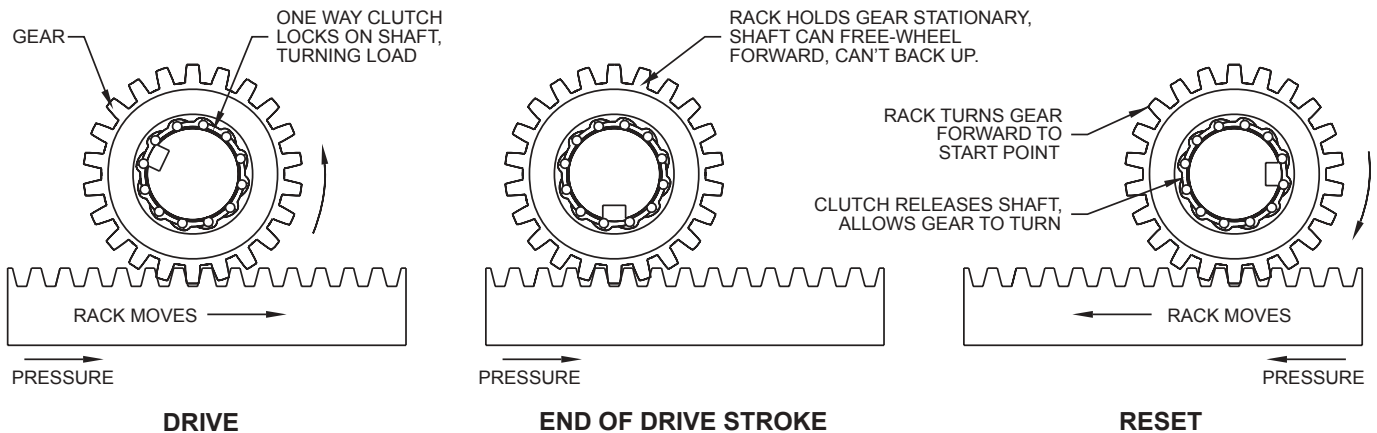

# STEPPING ACTUATORS MOUNTING DIMENSIONS

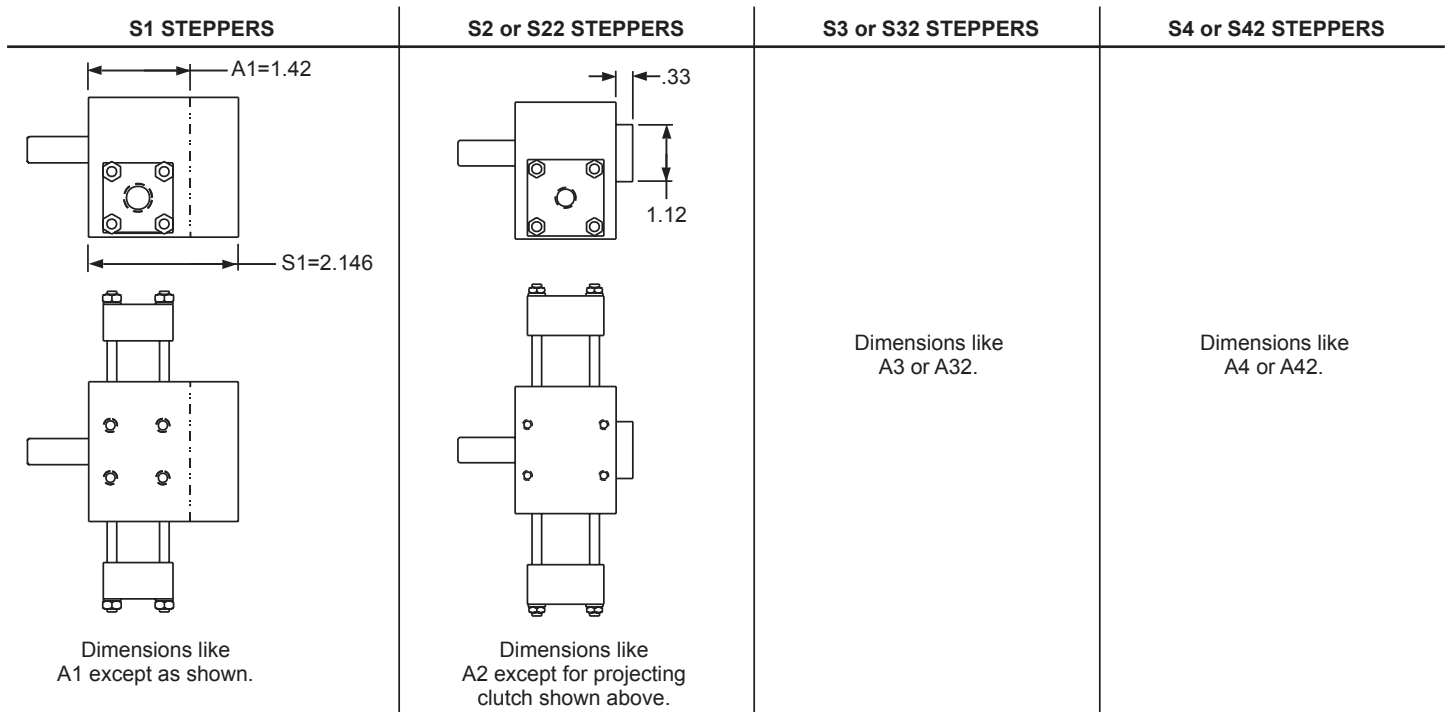

## STEPPING ACTUATOR RATINGS

	S1	S2	S22	S3	S32	S4	S42
Torque Factor: in. lb./p.s.i.	.153	.49	.98	1.49	2.98	3.46	6.92
Max. Working Pressure, p.s.i.:							
Air	150	150	75	130	65	120	60
Oil	300	150	75	130	65	120	60
Max. Torque: Non-shock, in. lb.	45	73	73	196	196	412	412
Max. Reverse Torque: Non-shock, in. lb.	23	37	37	98	98	206	206
Max. Thrust: Non-shock, lb.	40	75	75	150	150	200	200
Max. Radial Load: Non-shock, lb.	40	75	75	150	150	200	200
Displacement: in <sup>3</sup> /deg.	.0026	.0086	.0172	.026	.052	.060	.121
Weight 180 deg. std. unit: lb.-oz.	1-2	2-7	3-12	6-2	8-12	8-14	13-14



### HINTS ON USING A STEPPING ACTUATOR

The stepping actuator provides torque while rotating through its specified angle, always in one direction. It has no ability to slow or stop its load, so it will stop at a point determined by load inertia, friction, or external stops. The shaft can freewheel in the forward direction without restriction, so it has no fixed reference position. A one way clutch in the body prevents rotation in the reverse direction. Optional rotation adjusters can be used to set the stroke, and multiple stroke lengths can be obtained from a multi-angle actuator. The actuator can be stalled continuously by an external stop without problems.

Natural applications for the stepping actuator include:

- indexing applications where there is a high drag/inertia ratio and where error does not accumulate, such as driving a pinch roller to pull stock from a spool incrementally to be cut into lengths
- driving detented items such as rotary switches, cam sequences, etc
- those needing one-direction rotary motion with no position accuracy requirement, such as waste conveyors

### Torque Ratings

The maximum torque is limited by the roller clutches used to drive the shaft and to prevent reverse rotation. Exceeding the maximum working pressure specified may overload the clutch, reducing life and/or causing immediate failure. Dual rack actuators are intended for use in applications where the maximum torque rating of the clutch cannot be utilized on normal shop air. Please note that normal shop air may overload the clutch on a dual rack actuator.

Reverse torque from an external source can also damage the actuator if it exceeds the maximum torque rating.

### PRECISE POSITIONING/INDEXING

The stepping actuator can index even a high inertia load very precisely with a shot pin or other detent mechanism. The precision of the angle and load position is that of the detent system. This offers a number of advantages:

- The stop positions can be adjusted by adjustment of the detent position.
- Irregular, custom angle sequences are possible.
- The detent can be placed at a large radius to handle high inertia loads.

### LOAD POSITION STABILITY

The shaft and load are prevented from rearward motion by the drive clutch and by a similar non-return clutch installed between the shaft and body. However, the clutches offer no resistance to forward motion, so torques in that direction will displace the shaft and load. Unwanted forward motion can be prevented by a controlled clutch/brake. Such a device can be installed on the rear projection of a double ended shaft.

# GENERAL AND MOTION CONTROL OPTIONS

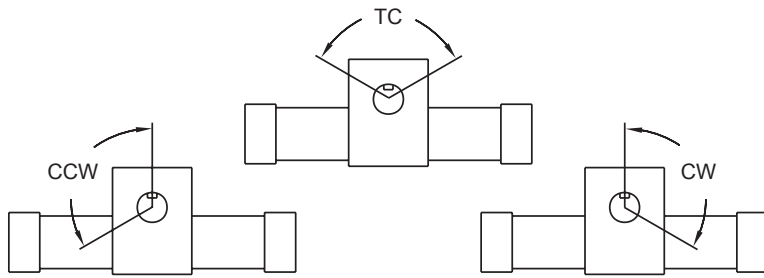

## ACTUATOR SHAFT KEYWAY MOTION

Symbols specify orientation of arc of motion looking at front of unit. In Top Center (TC), the keyway passes thru 12:00 o'clock (0 deg.) at the midpoint of rotation; one-half the rotation is on either side of 12:00 o'clock.

Symbol: TC, CW, CCW No cost option.

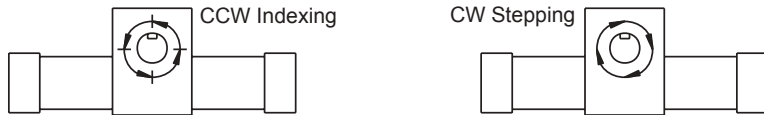

## INDEXING & STEPPING ACTUATOR SHAFT KEYWAY MOTION

Specify shaft rotation looking at the projecting, load-carrying shaft.

Symbol: CW, CCW No cost option.

Indexing actuator: steps in specified direction to hard stops.  
Stepping actuator: steps in specified direction, no hard stops. Accumulates error.

- Top 1
- Rear 2
- Bottom 3
- Front 4
- End 5

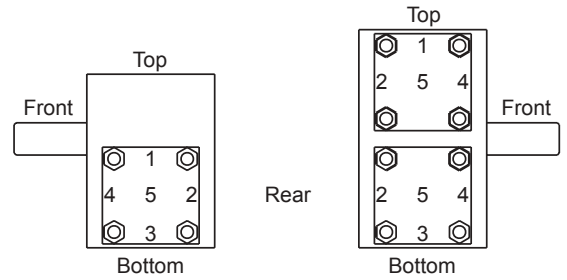

## PORT POSITIONS 1, 2, 3, 4, 5 NEEDLE VALVE POSITIONS 1, 2, 3, 4

(PORT & NEEDLE VALVE CANNOT BE AT SAME POSITION)

Use numbered locations to specify desired position. No port in position 5 with options A, F or C. No port or needle valve between end caps in dual rack units; for positions 90 from shaft, specify 1, 3 (top and bottom).

Symbols: 1, 2, 3, 4, 5  
No cost option.

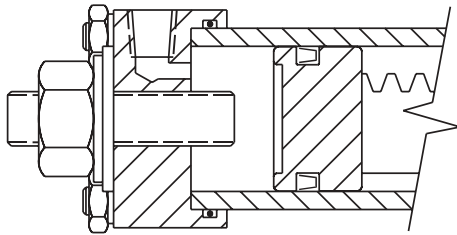

## ROTATION ADJUSTER

Adjustable stop controls rotation over 30 deg. range by stroke reduction. Can be combined with flow control or cushion in single rack actuators or steppers. Not available for indexers.

Symbol: A

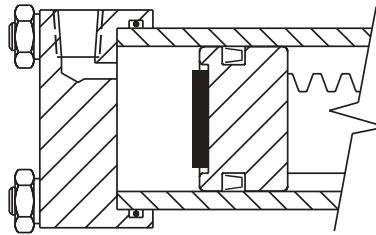

## BUMPER

A urethane bumper is fastened to the piston face. It eliminates metal to metal contact and absorbs shock. Requires added cylinder length.

Symbol: Q

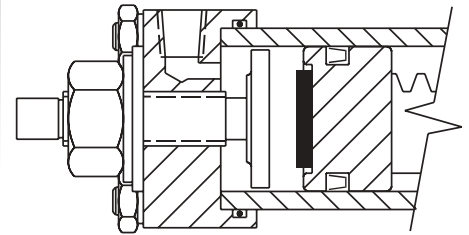

## ADJUSTER AND BUMPER

Combination of adjuster and bumper. Uses enlarged adjuster face to distribute impact. Requires added cylinder length.

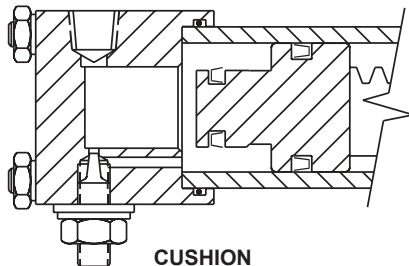

## CUSHION

A reversed U-cup on the auxiliary piston closes the free passage to the port, forces exhaust through the control needle valve over last 30 deg. of rotation. For return, pressure folds U-cup down, allows full pressure and flow to piston.

Not fully effective in drive direction in steppers or indexers because of overrunning clutch.

Symbol: C

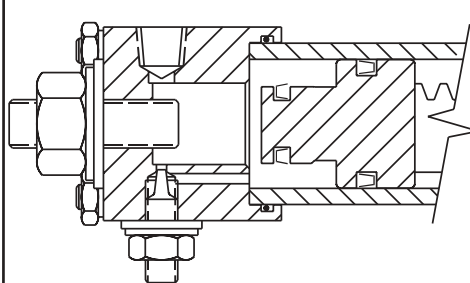

## ADJUSTER AND CUSHION

Combined adjuster and cushion for single rack actuators or steppers. Installed separately, cushion on top rack, in dual rack units. Stroke reduction also reduces cushion action.

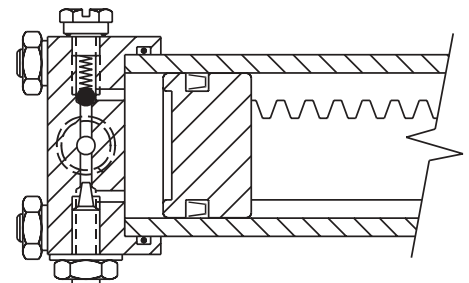

## FLOW CONTROL

Forces exhausting air to pass through control needle valve, limits operating speed throughout rotation in one direction. Check valve opens for full flow on return. Requires needle valve access; not available with port position 5. Intended primarily for air operation. Can be combined with rotation adjustment.

Symbol: F

# MOTION CONTROL OPTIONS



## THREE POSITION ACTUATOR

Uses internal stops for optional drive to any of three shaft positions in any sequence. Available in A12, A22, A32 and A42, but drives shaft with only one cylinder at a time; use torque factor for A1, A2, A3 or A4.  
Shown: A42-45-0-45-S11-C2-RR-1/4-1, 3

To specify the positions desired in a 3 position dual rack actuator:

1. Determine central reference position RP at 0j to 360j clockwise from 12:00
2. Determine angle CCW from RP: A
3. Determine angle CW from RP: B

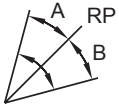

Specify: A-RP-B

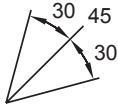

Example: 30-45-30

**NOTE: MULTI-POSITION ACTUATORS REQUIRE TWO MAGNETIC SWITCHES TO INDICATE EACH INTERMEDIATE POSITION.**



## AIR DAMPERS

Auxiliary cylinders and pistons with adjustable pressurization through a relieving regulator give soft deceleration at cycle rates higher than conventional shock absorbers can tolerate.

Consult factory.

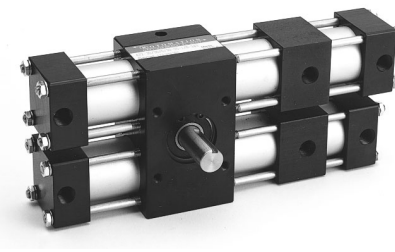

## FOUR OR FIVE POSITION ACTUATORS

Pairs of auxiliary cylinders and pistons with stop rods added to three position actuators provide additional intermediate stop positions. All positions are accessible in any sequence. Note that intermediate end caps are vented.  
Shown: four position A22-30/30-30-30-S5-1/8-4

### FOUR POSITION:

To specify the positions desired in a 4 position dual rack actuator with auxiliary cylinders:

1. Determine an inner reference position RP at 0j to 360j clockwise from 12:00
  2. Determine angle CCW from RP: A
  3. Determine angles CW from RP: B & C
- Enclose RP with dashes, separate others with slash.

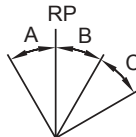

Specify: A-RP-B/C

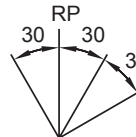

Example: 30-0-30/30

### FIVE POSITION:

To specify the positions desired in a 5 position dual rack actuator with auxiliary cylinders:

1. Determine the central reference position RP at 0j to 360j clockwise from 12:00
  2. Determine angles CCW from RP: A & B
  3. Determine angles CW from RP: C & D
- Enclose RP with dashes, separate others with slash.

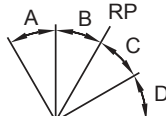

Specify: A/B-RP-C/D

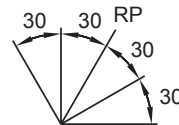

Example: 30/30-30-30/30

# CONSTRUCTION OPTIONS



## WASHDOWN UNITS

Shaft seals built into body or integral cover plates, cylinders sealed by O-Rings, assembly threads sealed, stainless shafts, anodized body and end caps.

Symbol: J

On order, hard chrome plated shafts, electroless nickel plated body and end caps.

## DUST RESISTANT UNITS

Units sealed against inward leakage  
Pressurization port

Symbol: Written description

## CLEAN ROOM CONSTRUCTION

Units sealed against outward leakage  
Body drain or purge ports  
Low vapor pressure lubrication  
Dry lubrication or wear rings

Symbol: Written description

## SPECIAL SEALS

High temperature or aggressive fluids: FKM  
Note bearing seal limitations.

Symbol: V

Minimum fluid leakage: Pretensioned seals.  
Check fluid compatibility. Note increased breakaway pressure.

Symbol: T

## HIGH PRESSURE CONSTRUCTION

For pressures to 750 psi. Steel cylinders (no magnetic switches), hydraulic pistons with backup rings or pretensioned seals as required. Thread inserts on tie rod anchors. Body drain if desired.

Symbol: HP

## HEAVY DUTY, DUST RESISTANT A4, A42, X4, X42

Sealed, non-pumping structure-dust stays out. Pistons: two PTFE wear rings, carboxylated nitrile seals.

Cylinders: hard chrome ID, epoxy OD or aluminum with hard coat ID.

Lube: extra-tacky air cylinder grease.

Symbol: A or K

## REAR MOUNT CONSTRUCTION X3, X32, X4, X42

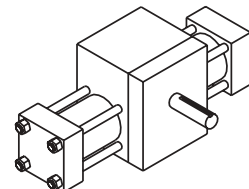

Shaft projects from rear; front mount holes opposite. Specify shaft rotation and options relative to shaft. Note reduced impact capacity page 29.

Symbol: B

# SIGNAL OPTIONS - MAGNETIC SWITCHES

## TIE ROD UNITS

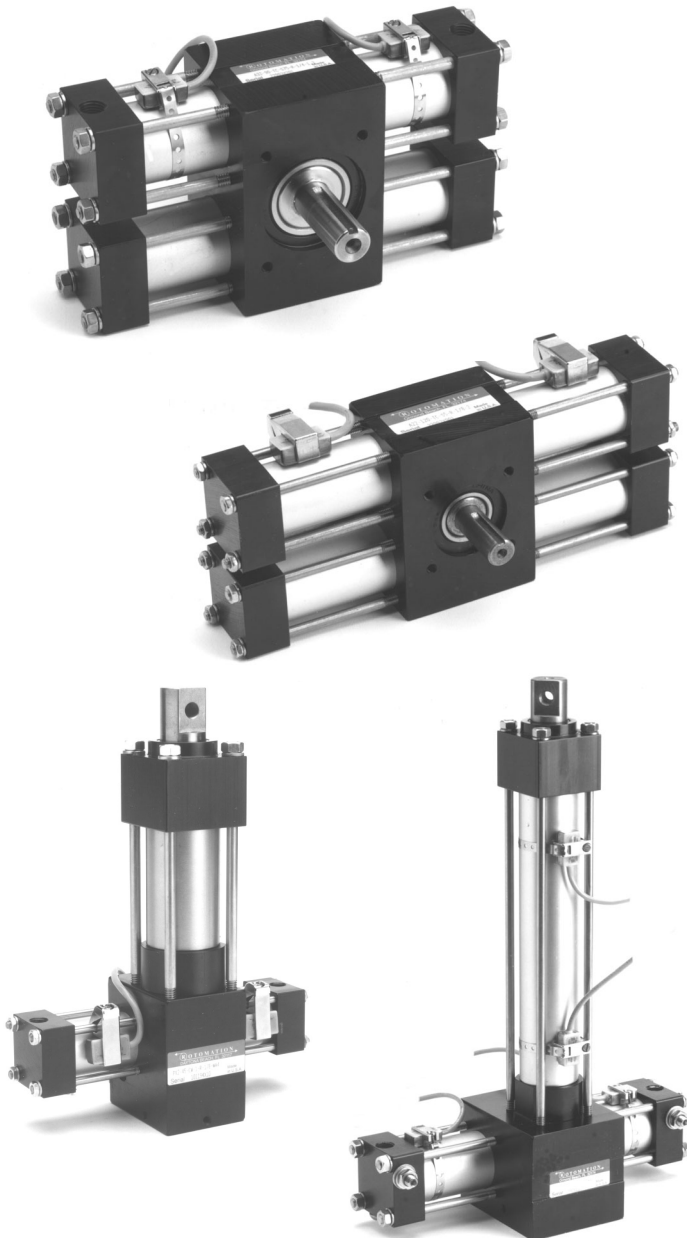

Two types of clamps are shown. Tie rod or strap clamps are supplied to fit best on the unit for which they are specified.

## UNITS WITHOUT TIE RODS

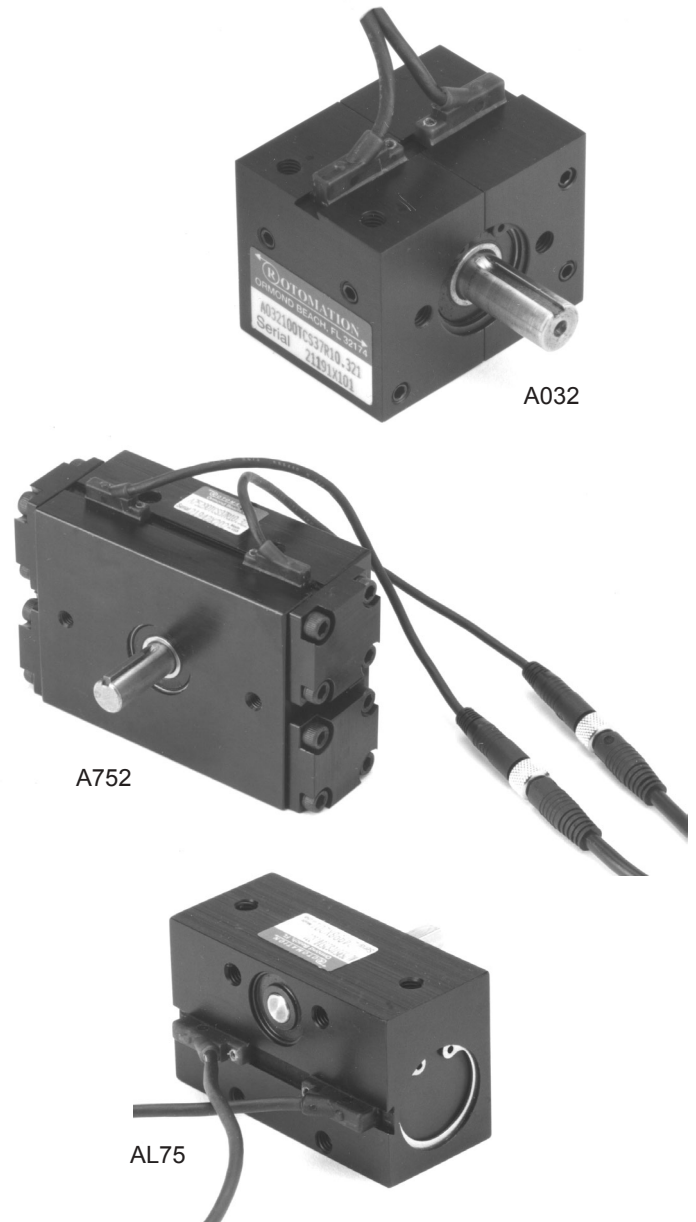

Switch position is adjustable along the integral track and locked by a hex socket set screw. Pigtail leads with connectors as shown on the A752 are optional on all switches; the extension cables should be ordered separately.

## SET UP AND OPERATION

Adjust switch position along exhausting cylinder to phase signal for desired sequence.

Adjustable range: 30 deg. or 1/2 stroke, whichever is smaller.

Keep magnetic materials away.

Multi-position actuators require two switches to indicate each intermediate position; a single switch will indicate each end position.

Rotomation piston magnets and switches are designed to work together. Magnets or switches may or may not work with components of other manufacture.

# MAGNETIC SWITCHES

## SWITCHES FOR TIE ROD UNITS

## SWITCHES FOR A032, A752 & AL75

## SWITCHES FOR PBM

	R	S	G	R	S	R	S
SWITCHING VOLTAGE	6-24 VDC	6-24 VDC	5-120 VAC/VDC	6-24 VDC	6-24 VDC	5-30 VDC	5-30 VDC
SWITCHING CURRENT	.5 A Max.	.5 A Max.	.5 A Max., .005 Min.	.20 A Max.	.20 A Max.	.20 A Max.	.20 A Max.
SWITCHING POWER	12 W Max	12 W Max	10 W Max.	4.8 W Max	4.8 W Max	6 W Max Resistive	6 W Max Resistive
VOLTAGE DROP	.5 V	.5 V	3.5 V	1.0 V Max.	1.0 V Max.	1.1 V Max.	1.1 V Max.
'R' NPN (Sinking)	L: 837-100-034 C: 837-100-134 SWITCH BRN GRN WHT LOAD 6-24 VDC POWER SUPPLY	L: 937-000-032 C: 937-000-332 SWITCH BRN BLK BLU LOAD 6-24 VDC POWER SUPPLY	L: 837-100-033 C: 837-100-133 SWITCH BRN GRN WHT LOAD 6-24 VDC POWER SUPPLY	L: 937-100-031 C: 937-000-331 SWITCH BRN BLK BLU LOAD 6-24 VDC POWER SUPPLY	L: 837-100-004 C: 837-100-104 N/A on A1, X1, S1 & PA01 SWITCH BRN WHT LOAD 5-120 V DC or AC POWER SUPPLY	SWITCH BRN BLK BLU LOAD 5-30 VDC POWER SUPPLY C: RC001	SWITCH BRN BLK BLU LOAD 5-30 VDC POWER SUPPLY C: SC001
'S' PNP (Sourcing)							
'G' Reed				N/A		N/A	

### SWITCH LEADS:

Description Specify

9 ft. PVC cable, 3 conductor, color coded.

L

6 inch. pigtail with 8 mm quick disconnect.

C

### EXTENSION CABLES - ORDER SEPARATELY

Cables have 8mm locking connector to connect to switches, above. 3 conductors color coded brown, black, blue.

Cable length	Part Number
2 m	CC2
5 m	CC5

### REPLACEMENT SWITCHES

Order by number adjacent to switch block in diagrams above. Switches with leads identified by L, those with pigtail and connector by C. Switches are tested before shipment and are **NOT** returnable.

Extension cables have same color coding as A032, A752 and AL75 switches above, right.

LED indicates switch operation.

Standard lead length is 9'; connector is on 6" pigtail.

Observe polarity; reversal will damage switch.

Observe maximum ratings; exceeding them will damage switch.

Reed switch has built-in surge protection; others do not.

Switches and cables resistant to moisture, dust and oil; designed to meet NEMA 4 specification.



## OTHER SIGNAL OPTIONS

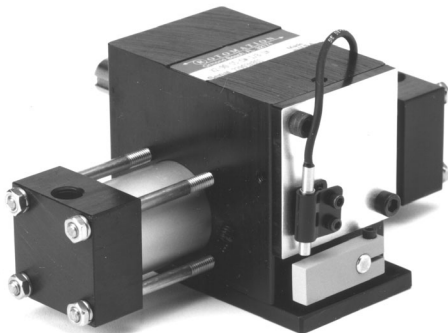

### INDEXING ACTUATOR EXTENDED PAWL SHAFT

Shaft rotates 7 deg. at index and reset. Arm actuates switch, prox detector or pilot valve. Dimensions: see □Design Your Indexing Actuator□ page 24.

### MAXIMUM LOAD TORQUE ON EXTENDED PAWL SHAFT

Unit	In. Oz.
X1 or X12	1
X2 or X22	2
X3 or X32	10
X4 or X42	17

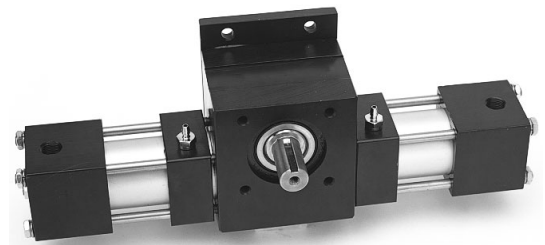

### SIGNAL PORT

For use in explosive or other atmospheres or with air logic controls. Ports provide line pressure signal at ends of rotation to actuate external devices. Fixed position, not adjustable.

# MOUNT PLATE OPTIONS

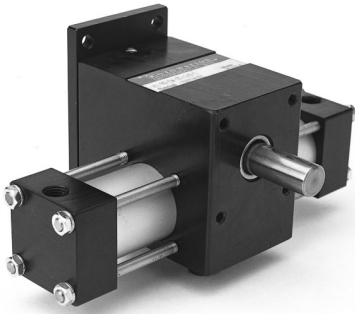

REAR MOUNT PLATE P



FRONT MOUNT PLATE N



BOTTOM MOUNT PLATE M

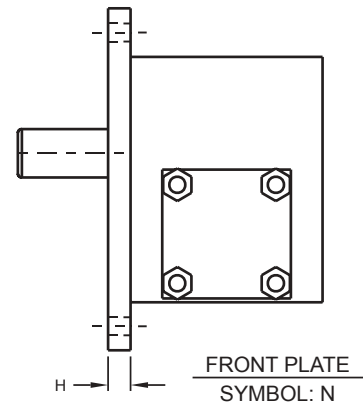
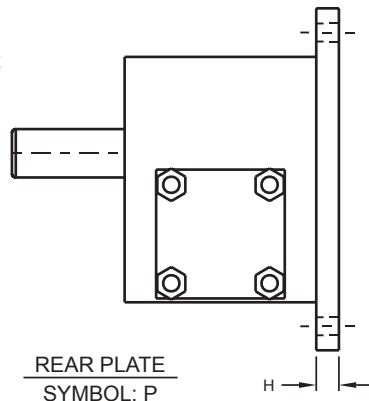
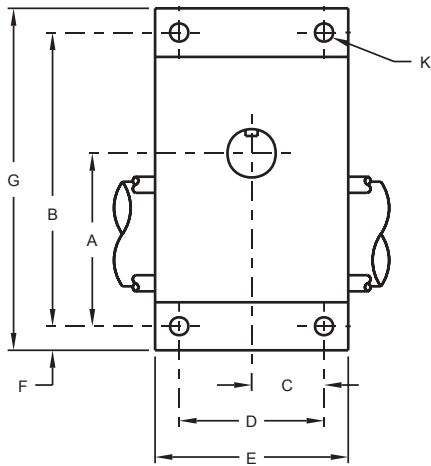

**INDEXING ACTUATORS:** Rear plate P fits X1, X12, X2, X22; for X3, X32, X4 & X42 specify BP: rear mount construction and plate.

**STEPPING ACTUATORS:** Rear plate P not usable on S2 OR S22; others ok.

**PICK AND PLACE ACTUATORS AND NITPICKERS:** Mount plate P (perpendicular to rod) same as listed plate for corresponding actuator or indexer.

## DIMENSIONS

MODEL	A	B	C	D	E	F	G	H	I	J	K	Z
A01	1.188	1.875	.313	.625	1.00	3/16	2.25	.175	1.375	1.75	3/16	.188
PA01	1.312	2.000	.750	1.500	2.00	1/4	2.50	.175	NA	NA	13/64	.188
A032	1.000	2.000	.750	1.500	2.00	1/4	2.50	.175	2.000	2.50	7/32	.250
A1	1.500	2.500	.750	1.500	2.00	1/4	3.00	.175	2.500	3.00	7/32	.563
S1	1.500	2.500	.750	1.500	2.00	1/4	3.00	.175	3.125	3.63	7/32	.563
A12	1.500	3.000	.750	1.500	2.00	1/4	3.50	.175	2.500	3.00	7/32	.563
X1	1.500	2.500	.750	1.500	2.00	1/4	3.00	.175	3.125	3.63	7/32	.250
X12	1.500	3.000	.750	1.500	2.00	1/4	3.50	.175	3.125	3.63	7/32	.250
A2 or S2	1.938	3.188	.750	1.500	2.50	1/4	3.69	.235	2.500	3.00	7/32	.250
A22 or S22	1.938	3.875	.750	1.500	2.50	1/4	4.38	.235	2.500	3.00	7/32	.250
X2	1.938	3.188	.750	1.500	2.00	1/4	3.69	.235	3.500	4.00	7/32	.250
X22	1.938	3.875	.750	1.500	2.00	1/4	4.38	.235	3.500	4.00	7/32	.250
A3 or S3	2.687	4.562	1.125	2.250	3.00	3/8	5.31	.350	3.750	4.50	9/32	.375
A32 or S32	2.687	5.375	1.125	2.250	3.00	3/8	6.13	.350	3.750	4.50	9/32	.375
X3	2.687	4.562	1.125	2.250	3.00	3/8	5.31	.350	4.500	5.25	9/32	.375
X32	2.687	5.375	1.125	2.250	3.00	3/8	6.13	.350	4.500	5.25	9/32	.375
A4 or S4	3.125	5.063	1.125	2.250	3.00	3/8	5.81	.350	3.750	4.50	11/32	.375
A42 or S42	3.125	6.250	1.125	2.250	3.00	3/8	7.00	.350	3.750	4.50	11/32	.375
X4	3.125	5.063	1.125	2.250	3.00	3/8	5.81	.350	4.750	5.50	11/32	.375
X42	3.125	6.250	1.125	2.250	3.00	3/8	7.00	.350	4.750	5.50	11/32	.375

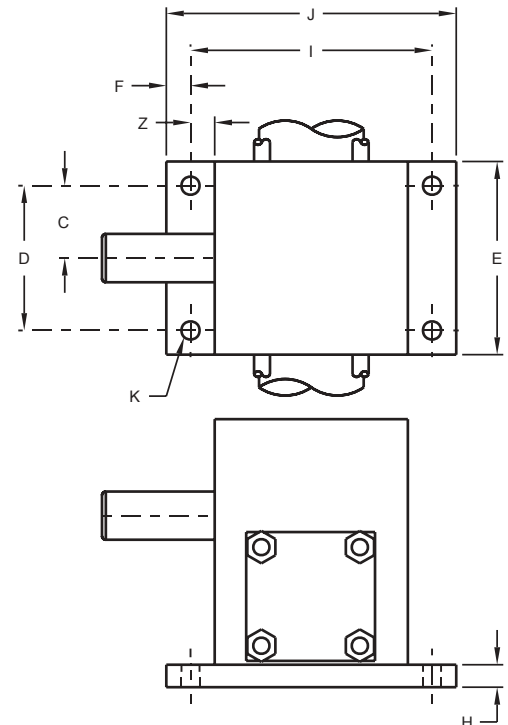

BOTTOM PLATE  
SYMBOL: M

# MATCH YOUR LOAD WITH SHAFT OPTIONS

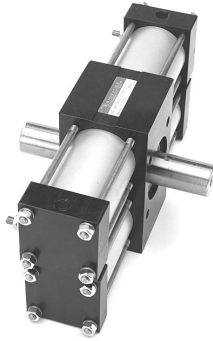

## DOUBLE END SHAFT

Shaft extends from the rear of the unit as well as the front. Rear projection dimensions same as front.

Symbol: D(SIZE)

A42-180-CCW-D11-3C2-1/4-1&3 shown.



## HOLLOW SHAFT

Provides compact coupling to load; dimension table below. Self aligning if mounted free on driven shaft with turnbuckle to absorb torque.

Symbol: HS(SIZE)

A42-180-TC-HS75-3C2-1/4-1&3 shown.

## PRELOADED KEYWAY

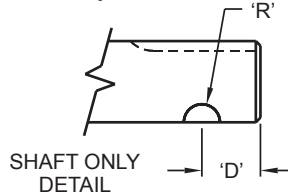
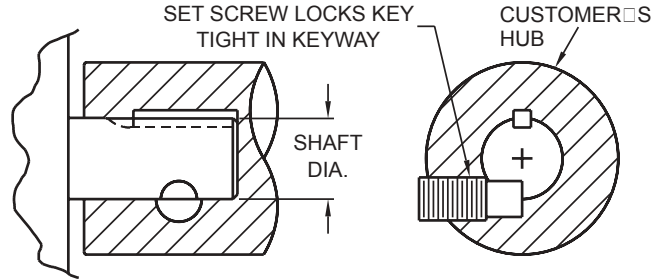

Unit Size	Shaft Dia.	'R'	'D'
1 or 12	.375	.125	.312
2 or 22	.500	.156	.375
3 or 32	.750	.188	.688
4 or 42	1.000	.250	.812
	1.125	.250	.812

Symbol: KK

## STANDARD AND OPTIONAL SHAFT CONFIGURATIONS

SHAFT DIAMETER:	3/16	1/4			3/8			3/8 ID	1/2		3/4			3/4 ID	1			1 1/8	
SHAFT SYMBOL:	S18	S25	D25	R25	S37	D37	R37	HS37	S5	D5	S75	D75	R75	HS75	S10	D10	R10	S11	D11
A032		O	O	O	S	O	O*												
A01	O	S	O																
A1 or A12		O			S	O		O											
S1					S														
X1 or X12					S	O													
AL75		S	O	O															
A752					S	O		O											
A2 or A22								O	S	O									
S2 or S22									S	O									
X2 or X22									S	O									
A3 or A32											S	O		O					
S3 or S32											S								
X3 or X32											S	O	O						
A4 or A42														O	S	O		O*	O
S4 or S42															S	O			
X4 or X42															S	O	O		

## REAR PROJECTING SHAFT A032

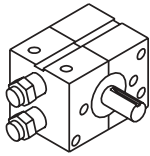

Specify options from front view of unit. Rear projecting shaft operates like rear half of double ended shaft.

Abbreviations: "S18" means "single ended shaft .188" (3/16") diameter; others similar.  
 "D18" means "double ended shaft .188" (3/16") diameter; others similar.  
 "R37" means "rear projecting shaft .375" (3/8") diameter; others similar.  
 "HS37" means "hollow shaft .375" (3/8") inside diameter; others similar.  
 "S" means "standard".  
 "O" means "optional".

\* No cost option; all other optional shaft configurations at slight additional cost.

## HOLLOW SHAFT

UNIT	SHAFT SYMBOL	SHAFT I.D.	KEYWAY	SHAFT O.D.	STD. BRG.	SET SCREW
A1, A12 & A752	HS37	.3755/.3765	3/32 X 3/64	.625	BRONZE	8-32
A2, A22	HS37	.3755/.3765	3/32 X 3/64	.750	BALL	8-32
A3, A32	HS75	.751/.752	3/16 X 3/32	1.378	BALL	10-32
A4, A42	HS75	.751/.752	3/16 X 3/32	1.378	BALL	10-32

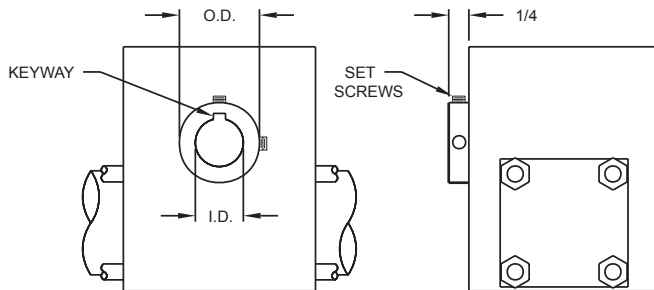

## SPECIAL SHAFTS:

Specify or sketch:

- Length or projection
- Diameter
- Keyway
- Drill or tap
- Retaining ring groove
- Bore
- Wrench flats
- Material
- Heat treat
- Plating

Most configurations in short time at low cost.

Ask for quotation.

# SHAFT MOUNTING ADAPTERS

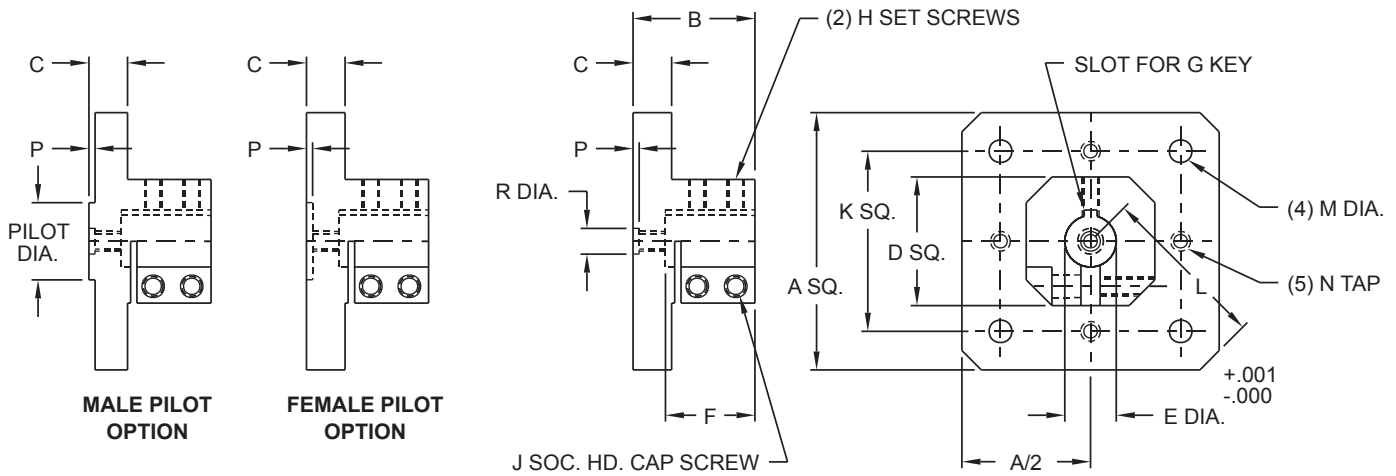

DIMENSIONS																
SIZE	SHAFT DIA.	A	B	C	D	E	F	G	H	J	K	L	M	N	P	R
37	.375	2.00	1.063	.313	1.00	.375	.750	3/32 X .75 LG.	6-32	#8-32	1.375	1.22	.219	#10-32	.060	.250
50	.500	2.50	1.188	.375	1.25	.500	.813	1/8 X .81 LG.	6-32	#10-32	1.750	1.64	.219	#10-32	.060	.250
75	.750	3.50	1.875	.500	1.63	.750	1.375	3/16 X 1.38 LG.	10-32	1/4-20	2.500	2.25	.281	1/4-20	.060	.313
10	1.000	4.00	2.125	.625	2.25	1.000	1.500	1/4 X 1.50 LG.	1/4-20	5/16-18	3.000	2.56	.406	3/8-16	.125	.438
11	1.125	4.00	2.125	.625	2.25	1.125	1.500	1/4 X 1.50 LG.	1/4-20	5/16-18	3.000	2.56	.406	3/8-16	.125	.438

## -ORDERING INFORMATION-

SMA - 50 - W - M.060



### SIZE

SHAFT DIA.	SYMBOL
.375	37
.500	50
.750	75
1.000	10
1.125	11

### HOLES

HOLES	SYMBOL
AS SHOWN	W
CENTER HOLE ONLY	N
USER SPECIFIED HOLES	SXXX FOR SPECIAL DRILL PATTERN

### PILOT

PILOT	SYMBOL
REFERENCE BORE ONLY	LEAVE BLANK
MALE PILOT	MX.XXX WHERE X.XXX IS PILOT DIA., INCHES
FEMALE PILOT	FX.XXX WHERE X.XXX IS PILOT DIA., INCHES

### NOTES:

1. Material: Clear anodized aluminum.
2. User specified holes: Send drawing. Factory will assign number XXX.
3. Adapters are stocked with no holes and with holes as shown. Special hole patterns and pilots are normally added after anodize and will expose bare aluminum.
4. Keyway is aligned with sides of plate. Reference bore 'R' is concentric with shaft bore within .001 inches.
5. Shaft mounting adapters shipped with key, clamp screws & set screws.
6. Pilot diameter tolerance is  $\pm .002$ .

